



500 series
carousel machines

Trepko

500 SERIES

The 500 Series from Trepko is designed around a carousel principle for handling pre-formed containers and provides a medium to high speed production output.

The flexible nature of the 500 Series allows for a variable machine length to suit the specified product. This flexibility permits a choice of several multi-fill applications with additional depositors for liquid, semi-liquid, dry products or simple hand placement areas. Different closing options are also available such as pre-cut foil, foil from reel & snap-on lids.

The carousel machines from TREPKO rely on a fully stainless steel construction which is combined with modern drive systems for a smooth and reliable operation. TREPKO also offers extra hygienic features CIP & SIP cleaning of both the dosing and/or packaging areas, in addition to an ULTRACLEAN version of the machine. Special efficiency support features, like magazine buffers for cups and lids are available to aid the operator and ensure reliable production levels.

The 500 Series machines are available in a single or twin lane format. The high adaptability levels of these machines is also reflected in a quick and easy changeover between different packaging sizes.



DESIGN EXAMPLE

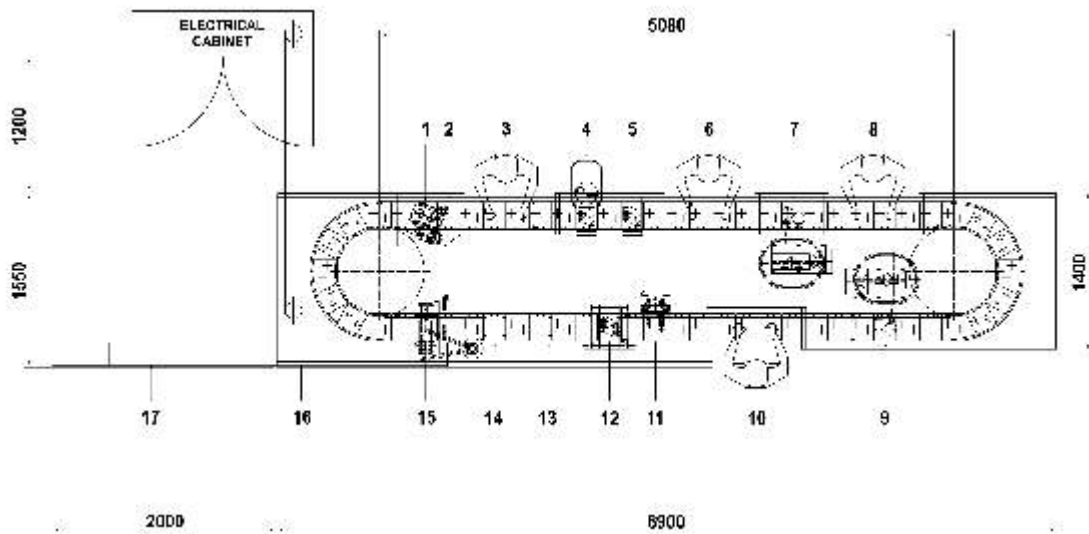

- | | | | |
|---------------------|---------------------|-----------------------|---------------------------------|
| 1. Cup Dispenser | 5. Crumb Tamp | 9. Toppings Depositor | 13. Date Coder |
| 2. Cup Detect | 6. Hand Placement 2 | 10. Hand Placement 4 | 14. Free space for Lid Dispense |
| 3. Hand Placement 1 | 7. Batter Depositor | 11. Foil Dispense | 15. Eject Lift & Sweep |
| 4. Crumb Feeder | 8. Hand Placement 3 | 12. Heat Seal | 16. Operator Control Panel/HMI |
| | | | 17. Eject Conveyor |

OPTIONS

PACKAGING HYGIENE

Sterile Air Cabin
Chemical Sterilisation of Cups / Foils
UV Radiation of Cups / Foils
CIP/SIP of the Dosing System
CIP/SIP of the Packaging Area
Gas Flush

INDIVIDUAL APPLICATIONS

Pre or Post-Depositors
Dry Product Fillers
Compensator
Marking
Modem

EFFICIENCY

Stack Feeding Magazine for Cups / Lids
Foil Sledge
Automatic Volume Adjustment

CLOSING

Pre Cut Foil Heat Seal
Snap-on-Lid
Foil from Reel

SPECIFICATIONS

• Machine Type	511	512
• Lanes	Single	Double
• Max. Cup Dimensions		
- Round (mm)	Ø 210	Ø 97
- Rectangular (mm)	180 x 180	100 x 60
- Depth (mm)		120
• Max. Output (cup/hr)	1,800	3,600
• Power Supply		3 x 400V + PE + N
• Compressed Air	30 m ³ /hr, 6 bar	36 m ³ /hr, 6 bar

Head Office

TREPKO A/S
Kuldysen 15-17
2630 Taastrup
Denmark
tel. +45 43 99 22 44
fax +45 43 99 26 55

United Kingdom, Ireland

TREPKO (UK) Limited
Marshall Way
Heapham Road Ind. Estate
Gainsborough, Lincolnshire
England, DN21 1GD
tel. +44 1427 612244
fax +44 1427 617797

Central & Eastern Europe

TREPKO Sp. z o.o.
ul. Roosevelta 116
62-200 Gniezno
Poland
tel. +48 61 426 50 41
fax +48 61 426 50 18

End of Line Solutions

TREPKO AB
Maskingatan 2-4
Box 551, 441 16 Alingsås
Sweden
tel. +46 322 66 86 00
fax +46 322 66 86 90

Middle East & North Africa

TREPKO A/S - Regional Office
P.O. Box 58
Al-Andalus 11817
Cairo - Egypt
mobile: +2012 32 19 274
tel./fax +202 227 34 613

North America

Trepko North America
W3835 Hwy H
Fredonia
WI-53021
USA
tel./fax +1 (262) 339-5482

info@trepko.com
www.trepko.com

World wide supplier
of **filling/closing machines**

